

# Density Balance Operation Manual

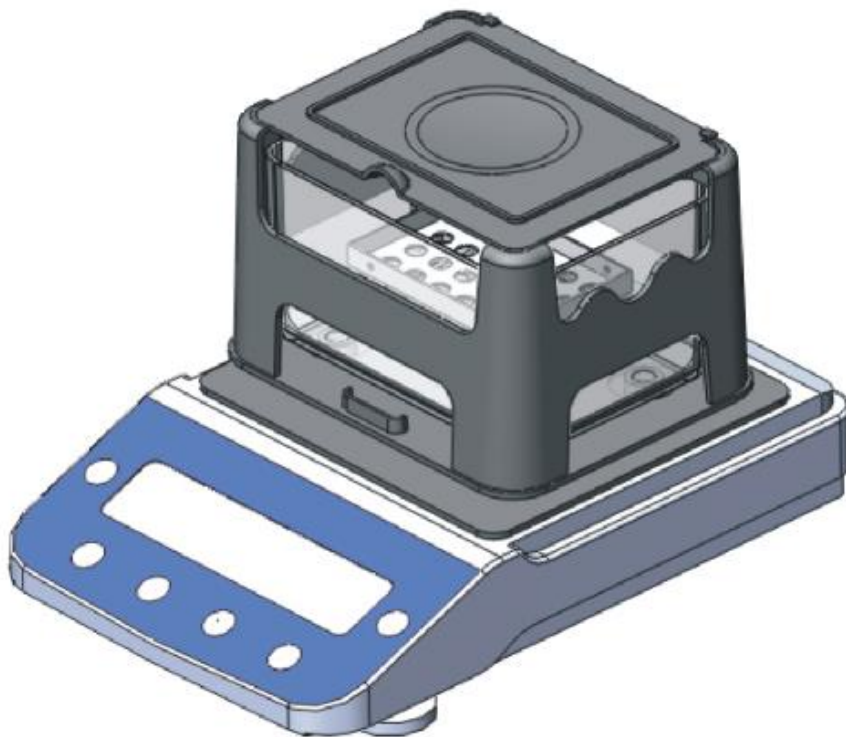

Please read the instruction manual carefully before using the instrument.  
Please keep the manual in a safe place for reference at any time.

## I、 Introduction and instrument description

### Principle:

Gold density Balance adopts the principle of Archimedes buoyancy method, which can quickly and accurately read the measurement value. For materials and products, two variables are mainly used to measure the relevant density values, and then calculate the gold purity and K number.

Based on a density of  $1.000 \text{ g/cm}^3$  at  $4 \text{ }^\circ\text{C}$ .

### Application

This machine is widely used in jewelry stores, banks, pawn stores, gold and precious metal research laboratories.

Max.capacity	600g
Weighing Accuracy	0.005g
Density Analysis	$0.001 \text{ g/cm}^3$

### Instrument Components



- ① Measuring table; ②、 Calibration weight; ③、 Host; ④Sink; ⑤、 Power supply;  
⑥、 Tweezers;

### Control Panel



1.  $\rightarrow 0 \leftarrow$ : A、 tare function;

B、 parameter setting number reduction function;

C、 setting switching function.

2. On/Off: Power on/off.

3. Cal : A、 calibration key;

B、 exit key after density measurement;

C、 function confirmation key;

4. Mode : A、 density measurement key;

B、 parameter setting number increase key;

5. F : Enter the function menu setting;

6.  : Transfer the display information to a printer or other device.

## II、 Installation Instructions

1. When installing, density tester should avoid in vibration, direct sunlight, strong magnetic fields, moisture overheating location.

2. Adjust the foot post to make sure the host reaches a horizontal position. Confirm that the inductor platform and water container support seat are not in contact.

3. Add distilled water to reach the water container water level line parts, and then the water container on the support seat.

4. Put the measuring table on the sensor platform, and confirm that the bottom of the measuring table is correctly placed on the sensor platform and the measured Basket sinks into the water. When air bubbles are attached to the hanging rail, use tweezers to remove the air bubbles.

Warm machine: power condition, AC 220V, 50Hz or 110V, 60Hz.

When plugged in and turned on the power supply, in order to make the instrument

reach a stable condition, need to warm up the machine for 10 minutes.

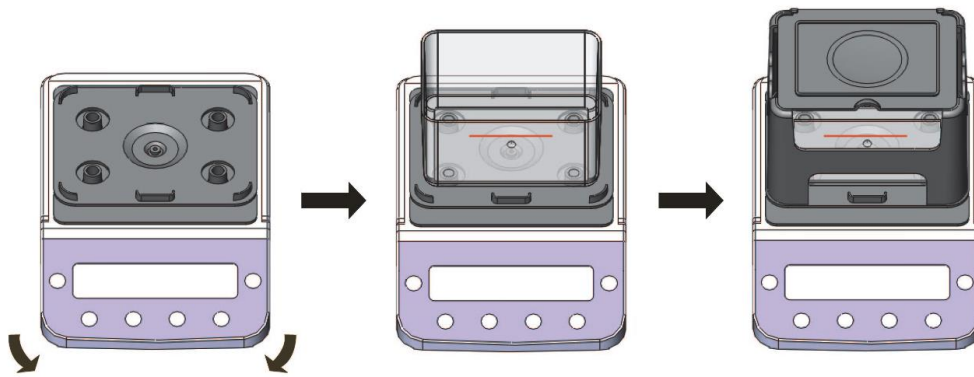

### III、 Calibration Instructions

The high-precision balance is installed in the density tester. The density of the sample is based on the calculation of the weight, and the accuracy of the measurement result comes from the accurate measurement of the weight. Depending on the characteristics of the density tester and its placement, its weight will be different. So it needs to be calibrated.

Calibration is required in the following cases:

- When used for the first time.
- when the instrument is moved elsewhere.
- when the environmental location is changed.
- periodic adjustments.

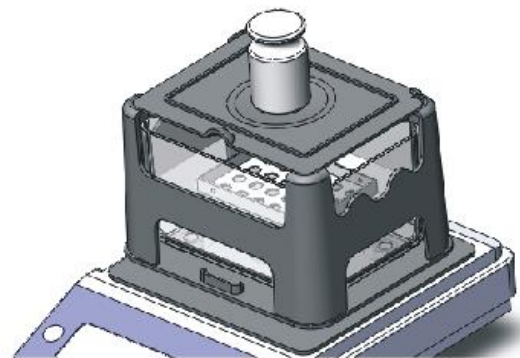

Calibration method: Use a 100g weight to calibrate.

1. Connect the power supply and warm up for 30 minutes (for cold areas);
2. In the weighing mode, press the CAL key, the screen will display 100;
3. Put the 100g weight on the instrument, press the MODE key, the screen will display ACAL(indicating that the calibration is in progress), when the screen displays 100.000, it

means that the calibration is completed. Pick up the weight to return to weighing mode.

※illustrate:

After calibration, if you move to another location, you need to re-calibrate.

#### IV、 Function Settings

##### (1) Temperature compensation setting

Press F key to display CEn719; press Mode key to display the value, which is the currently set solution temperature value. Press Mode key to increase the value; press →0← key to decrease the value. After setting, press Cal key, the value flashes and then press Mode key to confirm.

##### (2) Solution compensation (media parameter setting)

Press F to display CEn719. press →0← twice to display COEFF. Then press Mode to display COEFF1. Repeatedly press →0←, COEFF1 (medium density setting), COEFF2 (density setting of major elements in mixed metals), COEFF3 (density setting of minor elements in mixed metals), and SEC will be displayed in sequence.

After selection, press Mode key to display SET dp. Press →0← key, adjust the decimal point to the back of 7, and display SET. dp; press Mode key, it will display the density of the current medium. Press Mode key to increase the density; press →0← key to decrease the density. After setting, press Cal key, the value flashes, then press Mode to confirm.

##### (3) Gold and platinum mode switching

Press F key to display CEn719. Press "→0←" key to display SHAPE. Press MODE key, the screen displays goLd (Golden Modulus). Then press "→0←" key to switch the display of

PgoLd (Platinum modulus). Press "MODE" to confirm and return to weighing state.

Just above the middle of the screen displays "TARE", which means gold mode; "GROSS" means platinum mode; "COUNT" means tin alloy mode (with tin as the main element).

## V、 Measurement steps

Calculate the density based on Archimedes' principle. To avoid errors, the higher the density of the product, the heavier the weight required. Please refer to the following table to prepare sufficient sample weight.

	0.200	0.400	0.600	0.800	1.000	1.200	1.400	1.600	1.800	2.000	2.200	2.400
□□□g	0.16	0.62	1.41	2.56	3.93	5.65	7.7	10.1	12.7	15.7	19.0	22.7
	2.600	2.800	3.000	3.500	4.000	4.500	5.000	5.500	6.000	6.500	7.000	—
□□□g	26.6	30.9	35.4	48.2	62.9	79.6	98.3	118	141.6	169.9	200	—

## Cautions

### 1. Measurable samples:

Precious metals such as gold. The weight is more than 5g. The heavier the weight, the higher the accuracy;

Mixed metals or other alloyed metals;

Jewelry materials such as rings, necklaces, bracelets, straps, coins, etc.

### 2. Accurate results cannot be obtained in the following cases:

The sample has voids and air can't be excluded;

The sample surface is sticky with many air bubbles or dust and dirt.

When the surface of the sample is adhered to a mineral metal with almost the same specific gravity as the sample (gold = tungsten = 19.32).

### 3. In order to measure the accuracy, please pay attention to the following situations:

When installing, please install the accessories correctly according to the instruction manual;

Do not measure samples in places where there is wind and vibration;

The host must be placed in a flat place;

4. Measurement medium: Please do not use corrosive solution (alcohol can be used).

5. The instrument uses the specific gravity value to calculate the K number, density and purity of gold.

6. When measuring the weight in water, please put the sample into the water with a tweezer, so as to avoid water splashing and damaging the main board and the load cell.

A、 gold density, purity, K value measurement steps;

1. Power on and confirm whether it is in golden mode, refer to page 5 for mode switching;

2. The display will change from 9 to 0g. If the display is not 0.000g, press →0← to make it zero.

3. Put the gold on the tray table, press the Mode key after it is stable, the upper left of the balance shows HIGH, which means the weight of the gold in the air has been recorded;

4. Put the gold on the hanging table in the water, press the Mode key after it is stable, the machine will directly display the density of the gold.

SHA-Sg represents the density of gold; press →0← to switch the display in turn;

SHA-C1 represents the purity of gold purity; press →0← key to switch the display;

SHA-A1 represents the K number of gold; press →0← again to return to display density;

5. Press CAL to exit. You can continue to measure other products. If the exit shows 100, press the Cal key again.

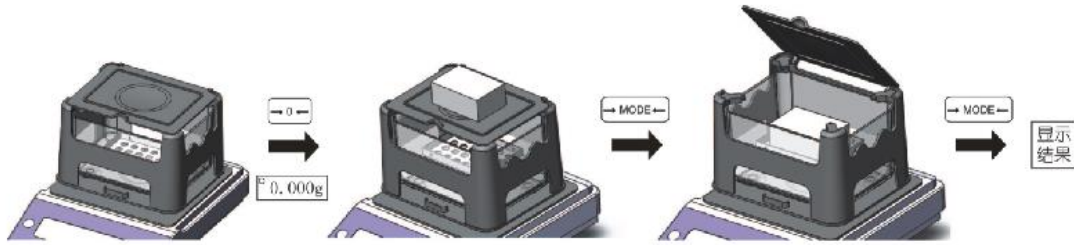

## B. Platinum PT value measurement steps;

1. Power on and confirm whether it is platinum mode, refer to page 5: mode switching.
2. The display will change from 9 to 0g until the instrument displays 0.000.
3. Put the platinum on the tray table, press the Mode key after stabilization, the upper left of the balance shows HIGH, which means the weight of platinum in air has been recorded;
4. Put the platinum on the hanging platform in the water, press the Mode key after it is stable, and the machine will directly display the density value.

SHA-Sg represents the density of platinum; press  $\rightarrow 0 \leftarrow$  to switch the display in turn.

SHA-C1 represents the purity PT value of platinum (including palladium); press  $\rightarrow 0 \leftarrow$  to switch the display.

SHA-A1 represents the purity PT value of platinum (including nickel); press the  $\rightarrow 0 \leftarrow$  key again to return to the display density.

Press CAL to exit. You can continue to measure other products.

If after exit, display 0, then press the Cal key.

## C. Tin alloy density and purity measurement steps

1. Power on and confirm whether it is in tin alloy mode, refer to page 5: mode switching;
2. The display will change from 9 to 0g, until the instrument displays 0.000;
3. Put the tin alloy on the tray table, press the Mode key after stabilization, and HIGH is displayed on the upper left of the balance, which means the weight of the tin alloy in the air



has been recorded;

4. Put the tin alloy on the hanging bar in the water, press the Mode key after it is stable, and then the machine will directly display the density value.

SHA-Sg indicates the density of tin alloy; press  $\rightarrow 0 \leftarrow$  key to display;

SHA-C1 represents the purity % of tin alloy; press  $\rightarrow 0 \leftarrow$  key again to return to display density;

Press CAL to exit. You can continue to measure other products.

## VI、 Troubleshooting

(1)、 Unstable weight:

Remedy: Remove the measuring table and the water tank to see if there are foreign objects or water droplets under the support table. If there are foreign objects or water droplets, please remove the foreign objects or wipe the water droplets clean.

(2)、 if the screen displays ----- or -E

Remedy: Press  $\rightarrow 0 \leftarrow$  to see if it will return to zero stably. If it does not return to zero, first remove the object on the measuring table, and then contact the manufacturer for maintenance.

(3)、 If there is a fault that cannot be eliminated by yourself, do not open the machine without authorization, please contact the manufacturer for maintenance.

(4)、 If the measured density value is always a value, or the measured density always displays 0.000, please set the temperature compensation to 25 and the solution compensation to 1.

(5) The following display information indicates some common faults:

----- Indicates that the electronic balance cannot get a stable reading.

HHHHHH The weight exceeds the rated weight by 5% or more.

LLLLLL a. The weighing pan is not installed. After installation, press →0← to clear it.

b. There may be sundries under the weighing pan, please check and make sure that the weighing pan is not in contact with the housing.

NOCAL The calibration procedure cannot be performed. Refer to the calibration function to check whether the calibration weight is correct and intact, and check whether there is any debris under the weighing pan.

UNABLE The electronic balance cannot perform the desired function due to missing or incorrect data.